

Smart Solutions. Powerful Products.



Wrangler™ Roughneck 80

Wrangler™ Roughneck 80

Designed for performance and reliability, the Wrangler™ Roughneck 80 takes on the toughest job on an oil rig – making up and breaking out drillpipe, drill collars and BHA's – and still has more than enough torque to make and break bits. Its robust design means maintenance is easier.

The WR 80 is used in the make up and/or break out of drilling tubulars at either the well center or the mousehole. It is pedestal is equipped with a hydraulically released lock for well center and multiple mousehole locations. The WR 80 is easily rotated allowing it to effectively reach both locations.

The efficient WR 80 is hydraulically powered, light weight, and spins up tubulars with high torque spinning motors. It torques up and breaks out drill pipe and collars utilizing an adjustable clamping force feature on the gripping cylinders. Limiting clamping pressure reduces tool joint box deformation, which means accurate torque in every connection.

The design also provides a thread compensation system with 1 1/2 inches of travel while spinning in or out. With an optional Bit Breaker kit, the WR 80 becomes the one tool that exceeds all others in its class.

Benefits

- Bit Breaking Option
- Spinning Wrench Thread Compensation
- Adjustable Clamping Force
- Extended 100" Reach
- Uses Standard Industry Dies
- Right or Left Hand Controls with Remote Control Option
- Unique Position Memory Feature
- Can Fit into Existing Floor Socket

Features

- Make-up Torque: 60,000 ft-lbs
- Break-out Torque: 80,000 ft-lbs
- Torque Range: 27°
- Torque Wrench Size Range: 3 1/4 to 8 1/2"
- Spinner Size Range: 2 7/8" to 8 1/2"
- Spinner Torque (5 1/2 Pipe): 2,000 ft-lbs
- Spinner Speed (5 1/2 Pipe): 82 RPM
- Weight: 5,800 lbs
- Bit Breaking: Yes
- Hydraulic Pressure: 2,500 PSI
- Hydraulic Flow: 26 GPM
- Horizontal Travel: 73"

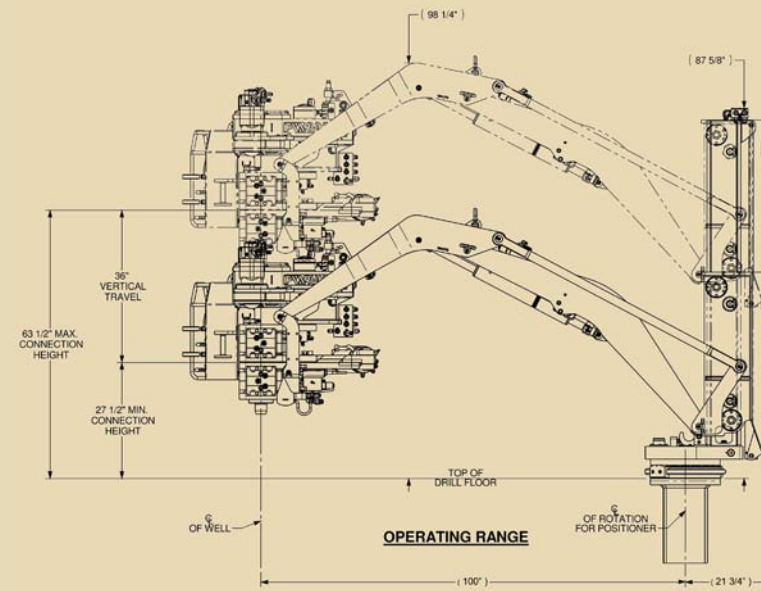

Maximum Bending Moment < 36,000 ft-lbs at Full Extension

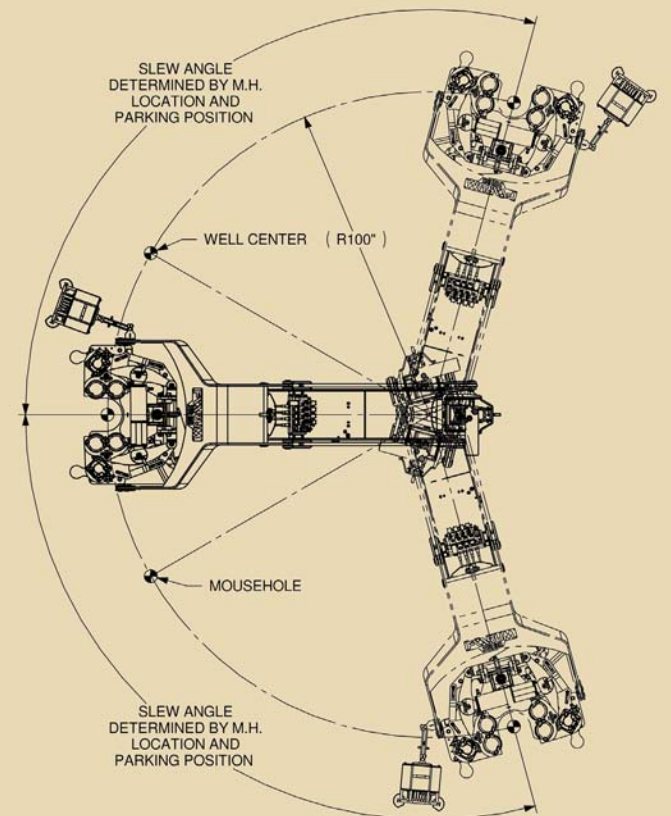
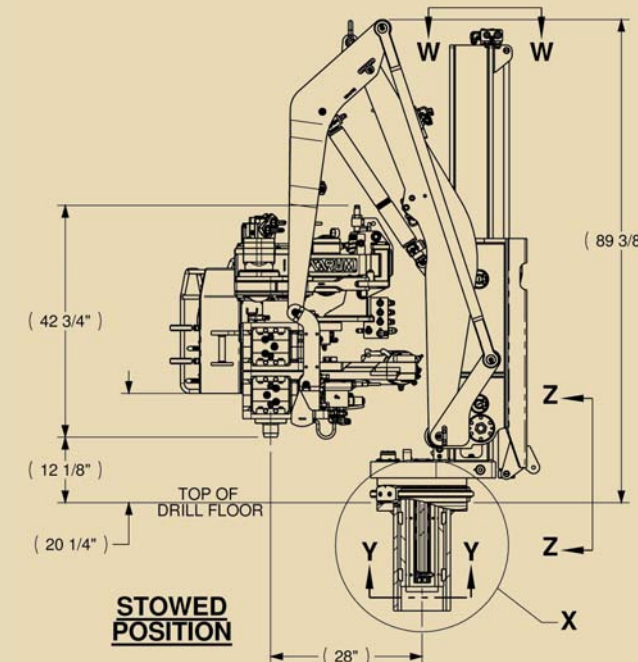
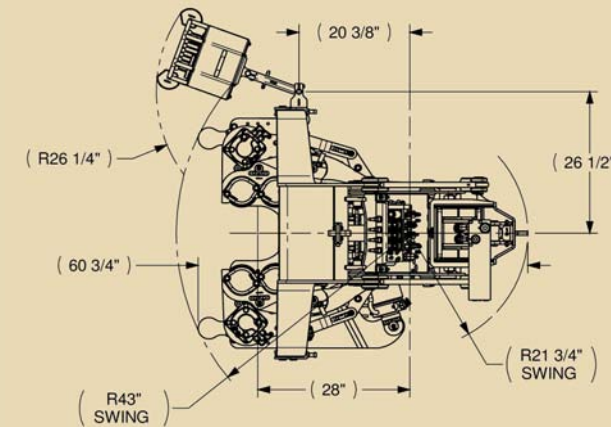
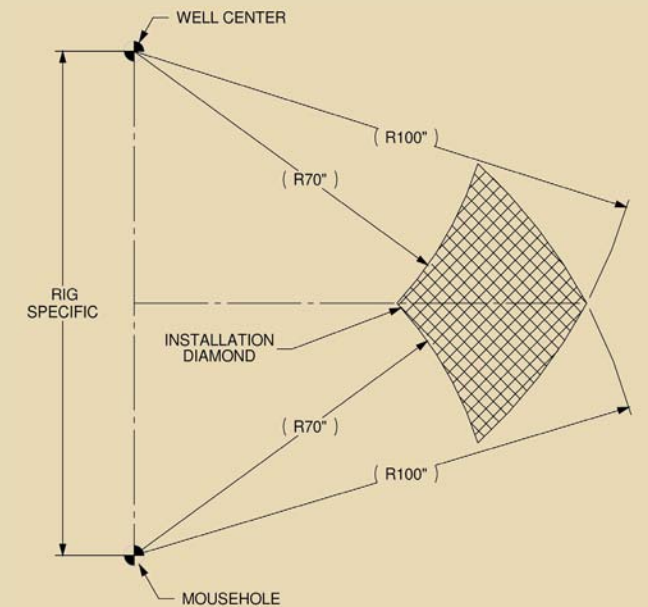

Our goal is to become the leading provider of mission critical oilfield products and related services in terms of customer satisfaction, safety and financial performance.

Our experienced management team and employees are dedicated to solving our customers' problems. We invest in long term relationships and cooperate on product development with our clients, we consider them our partners.

OUR CORE VALUES

No one gets hurt: The safety of our employees and customers is our first priority coupled with a healthy respect for the environment.

Integrity: In everything we do, in every interaction, both internally and externally, we strive to operate with the upmost integrity and mutual respect.

Customer focused: Our products enhance our customer's performance and we listen to their needs and work with them to solve their challenges.

Good place to work: We are committed to creating a workplace that fosters innovation, teamwork and pride. Every team member is integral to our success and is treated equally and fairly.



DRILLING TECHNOLOGIES HEADQUARTERS
10344 Sam Houston Park, Suite 300
Houston, TX 77064
713.351.7900 713.351.7997 [f]
f-e-t.com/Drilling

For a complete list of our locations visit: f-e-t.com/contact-us

DRL1003.1.18.16