



500/650 HCI 1205 Top Drive



A versatile top drive for high performance applications

The HCI top drive system is the most versatile top drive in the TESCO product line.

Compact enough to fit into most double and triple masts for land based applications or offshore derricks, the HCI provides the performance and pipe handling features required for medium and deep drilling applications.

TESCO powers the HCI using industry proven prime movers and its own series of hydraulic pump drives and filtration equipment.

The HCI top drive is available with an optional integrated swivel or can use the customer's swivel. Casing load ratings of 500 or 650 tons are available.

Performance (torque and speed) can be customized using optional gear ratios and power unit selection.

Value Added Operational Benefits:

- The complete system including the top drive, torque system, and power unit can be installed in less than one day. In most cases, no rig modifications are necessary.
- The HCI offers an expanded suite of pipe-handling functions including elevator link-tilt, and extend/retract feature for making mousehole connections (maximum extension 60 in.), 360° pipe-handler rotation, and grabber.
- The HCI grabber acts as a back-up tong for making or breaking connections and will accommodate tool joints from 3 inch to 8-3/4 inch outer diameter.

- TESCO's unique quill design allows rapid field removal for inspection or replacement without draining the gear case.
- The HCI is equipped with an independent diesel engine or traction motor.
- A double ball mud saver/safety valve is incorporated into the system design.
- The speed/torque ranges are selectable from the driller's console.
- The HCI track/torque bushing configuration is simple to install and requires minimal maintenance.
- The entire HCI can be transported in three standard 20 feet sea containers.

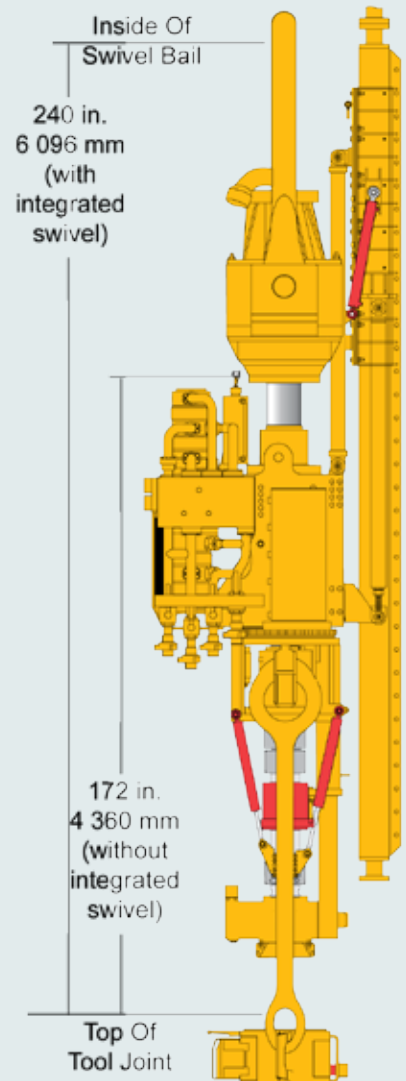
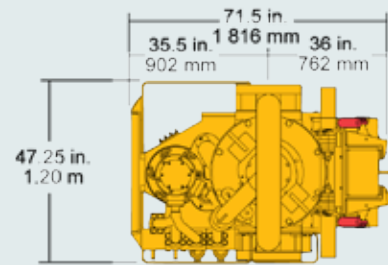
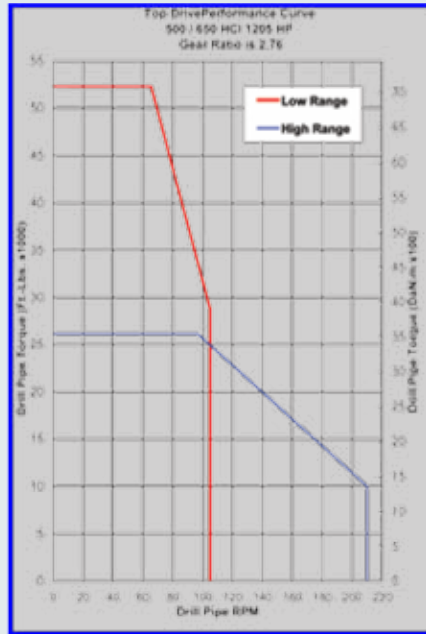

Specifications

500/650 TON HCI 1205 HP (with optional integrated swivel)	Imperial	Metric
Rated Capacity	500/650ton	454/590tonne
Rated Input Power	1205HP	900kW
Estimated Weight with swivel	19,300lbs	8,770kg
Operating Length (including 9ft. links, elevators & swivel)	240in	6,096mm
Width	47.25in	1,200mm
Max. Continuous Drill Torque	52,800ft-lb	7,158daN-m
Make-up Torque	52,800ft-lb	7,158daN-m
Breakout Torque	59,400ft-lb	8,053daN-m
Max Speed	210RPM	210RPM
Quill ID	2.5in	63.5mm
Power System		
Weight - (approximate)	36,000lbs	16,400kg
Length - (with hose reel)	420in	10,670mm
Width	6.25in	1,910mm

All specifications are subject to change without notice.

Asia Pacific

Jakarta, Indonesia
Email: APBU_sales@tescocorp.com

China

Chaoyang District, Beijing
Email: CHINA_sales@tescocorp.com

Europe/Russia

Moscow, Russia
Email: EURO_sales@tescocorp.com

Latin America

Mexico City, Mexico
Email: LABU_sales@tescocorp.com

Middle East & Africa

Dubai, UAE
Email: MABU_sales@tescocorp.com

United States/Canada

Houston, Texas/Calgary, Alberta
Email: NABU_sales@tescocorp.com

